

RoHS Compliant

3114 SERIES D-SUB CONNECTOR,
FEMALE TYPE 15P

REV	DATE	DESCRIPTION	ECN NO.	NAME
A	09.12.25	NEW RELEASE		Wzbin
B	10.05.07	△ MODIFICATION	CECR10005077	ZPEI
B1	14.07.28	△ MODIFICATION		LRP

MATERIAL:
HOUSING: PBT+30%G.F (UL94V-0)
HOUSING COLOR: BLACK
COVER: PBT+30%G.F (UL94V-0)
COVER COLOR: BLACK
TERMINAL: BRASS
TERMINAL PLATING: GOLD FLASH IN CONTACT AREA, 80u" min. Sn IN SOLDER TAIL AREA, BOTH OVER 30u" min. Ni UNDERPLATE OVERALL

SHELL: SPCC
SHELL PLATING: Ni PLATED
BOARDLOCK: SPCC
BOARDLOCK PLATING: Sn PLATED

△ SHIELD: BRASS
SHIELD PLATING: Ni PLATED
SCREW: BRASS
SCREW PLATING: Ni PLATED

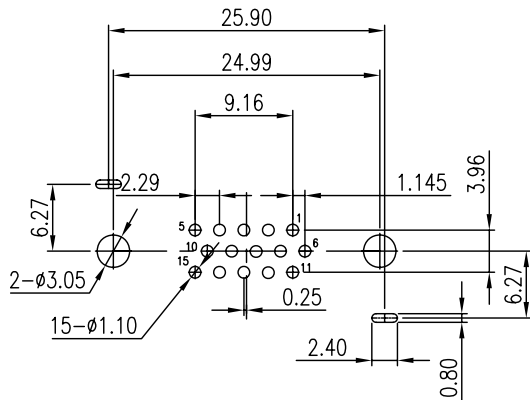
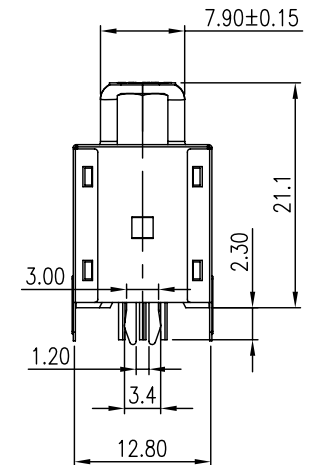
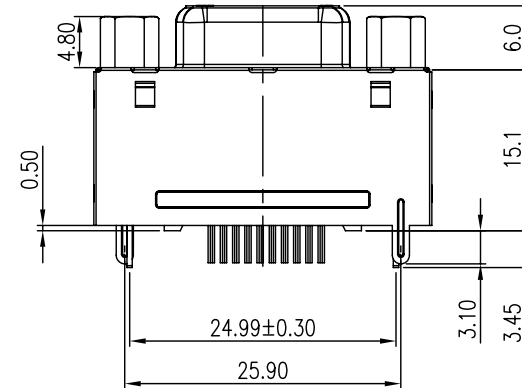
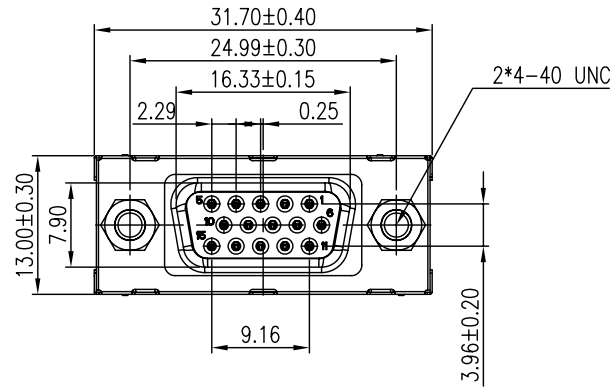
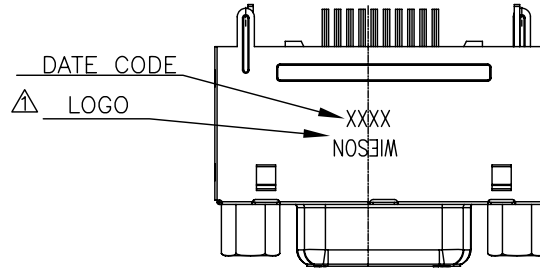

RECOMMENDED P.C.BOARD
TOP VIEW

NOTE: P.C.B. LAYOUT TOLERANCE: ±0.05mm

GENERAL TOLERANCE ±0.25	WIESON TECHNOLOGIES CO., LTD WIESON		PART NO.: G3114-130000101-00	
	DRAWN BY	Wzbin(WSC)	DRAWING NO.	G3114-130000101-00
GENERAL ANGLE TOLERANCE ±2°	CHECKED BY	JACK	DRAWING SIZE	A4
	APPROVED BY	KEVIN	UNIT	mm
⊕	SORTING NO.	CA0009(WSC)	PAGE	1 OF 1

ISSUED